

UNI-MAXST

Operation Manual

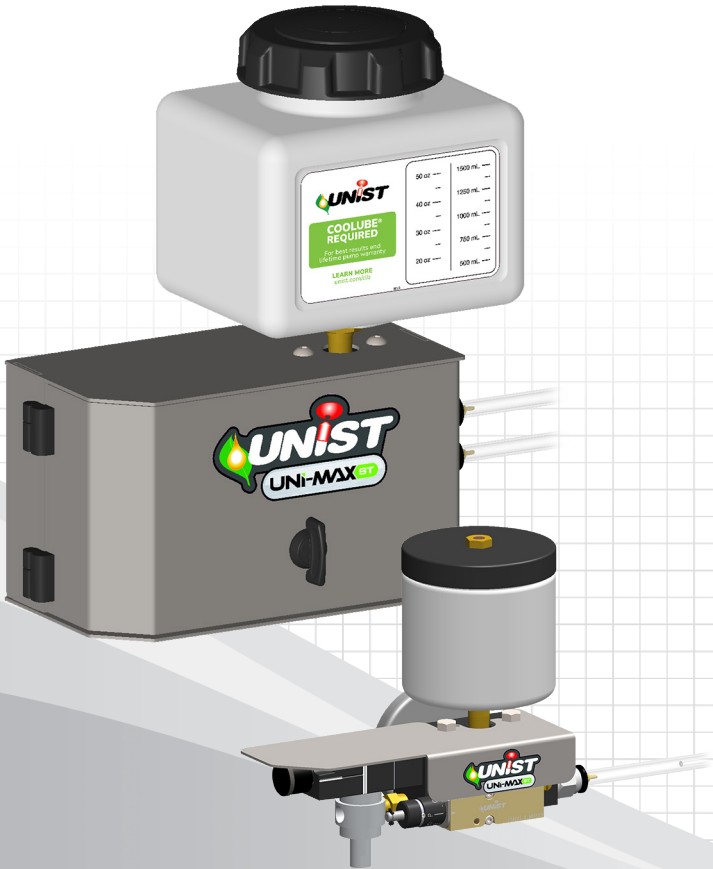



unist.com/stman



Questions or part orders:

1-800-253-5462 (US & Canada)
1-616-949-0853 (International)

Uni-Max® ST Operation Manual
Copyright © 2025 Unist, Inc.
07/30/2025 V1.2

1 Mount system

Systems with enclosure



OR



Direct mount

1/4-20 fasteners included for threaded inserts or keyholes

Magnet mount

Shown with optional enclosure magnet mounting kit (part number 305956)

Systems without enclosure

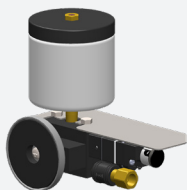

OR

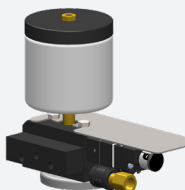

OR

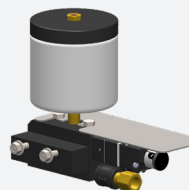

Rear magnet mount

Factory-installed, rear-facing magnet

Bottom magnet mount

Magnet installed in bottom-facing position

Direct mount

Through holes for included 3" 1/4-20 fasteners

2 Supply power to control valve (if applicable)

Wire the solenoid valve DIN connector to a power source, confirming proper voltage.

This will power the system on (see pg. 11 for more details).



Quick Start Guide

3 Supply air

Connect clean, dry, compressed air at 80–100 psi [5.5–7 bar]
(See pg. 11 for more details).

Systems with enclosure



Systems with chip guard

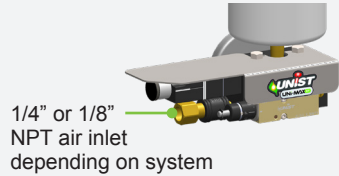

Systems with air pilot option



4 Provide fluid

See page 12 for more details.

**COOLUBE®
REQUIRED**

For best results and
lifetime pump warranty

Fill reservoir



or

Connect pressurized fluid supply (15 psi [1.0 Bar] max)

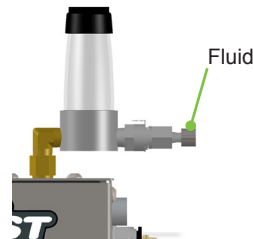

5 Mount nozzle(s)

Install nozzles with magnet (if included) or hard mount with appropriate fastener. Nozzle tips should be as close as possible to the cutting edge, ideally within 2" [50.8 mm]. Carefully route tubing to avoid cuts or kinks (See pg.14 for more details).

6 Set initial atomizing airflow

- Rotate the air metering screw clockwise until it is fully seated, then:
 - Back screw off 1/4–1/2 turn (45°–90°) for single-line systems (1/8" tubing).
 - Back screw off 1/2 – 3/4 turn (180°–270°) for coaxial systems (3/8" tubing with 1/8" inner tubing).

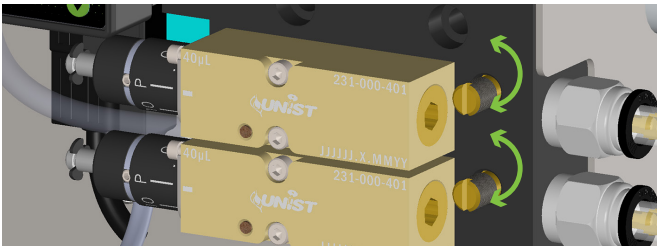

7 Actuate the air valve to start applying lubricant

Pumps will cycle at 10 strokes/minute (factory setting). Verify adjustable pumps are set to "P" to ensure self-priming.

Adjust atomizing airflow for ideal nozzle spray pattern. Excess airflow will cause undesirable fogging! (see page 22 for more details)

Adjust pump cycle rate to change lubricant output (see page 19 for more details). For long tubing lengths, it might take multiple pump cycles to see fluid at the nozzle tip.

Refer to page 25 for recommended application settings.

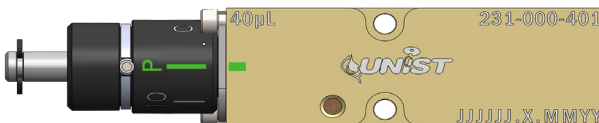

Adjustable output pump set to "P" (priming) position

Important operator information



Consult this documentation in all cases where this caution symbol appears. This symbol is used to inform you of any potential HAZARD or actions that require your attention.

Use of this equipment in a manner other than that specified by Unist, Incorporated may compromise design integrity and become unsafe.

WARNING: This equipment is not intended for use in explosive environments.

ADVERTENCIA: Este equipo no está diseñado para uso en atmósferas explosivas.

AVVERTIMENTO: Questa apparecchiatura non è inteso per l'uso in ambienti esplosivi.

WARNUNG: Das Ausrüstung darf in einer explosiven Umgebung NICHT verwendet werden.

AVERTISSEMENT: Cet équipement n'est pas prévu pour une utilisation dans des environnements explosifs.



WARNING: This product can expose you to chemicals, including lead, which is known to the State of California to cause cancer, birth defects, or other reproductive harm. For more information go to www.p65warnings.ca.gov.

ADVERTENCIA: Este producto puede exponerlo a productos químicos, incluido el plomo, que el estado de California sabe que causan cáncer, defectos de nacimiento u otros daños reproductivos. Para obtener más información, vaya a www.p65warnings.ca.gov.

AVVERTIMENTO: Questo prodotto può esporre a sostanze chimiche, incluso il piombo, che è noto allo Stato della California come causa di cancro, difetti alla nascita o altri danni riproduttivi. Per ulteriori informazioni, visitare www.p65warnings.ca.gov.

WARNUNG: Dieses Produkt kann Sie Chemikalien, einschließlich Blei, aussetzen, von denen der Staat Kalifornien weiß, dass sie Krebs, Geburtsfehler oder andere Fortpflanzungsschäden verursachen. Weitere Informationen finden Sie unter www.p65warnings.ca.gov.

AVERTISSEMENT: Ce produit peut vous exposer à des produits chimiques, y compris le plomb, qui est connu par l'État de Californie pour causer le cancer, des malformations congénitales ou d'autres problèmes de reproduction. Pour plus d'informations, visitez www.p65warnings.ca.gov.

Identifying Symbols



Caution - ISO 7000-0434B

Table of Contents

System Introduction	1–8
System identification & support.....	1
System function	2
Common system layout	3
System specifications	4
Pump specifications	5
Solenoid valve specifications	8
System Installation	9–13
Position & mount system	9
Mounting a system with enclosure	9
Mounting a system without enclosure	9–10
Air supply & control	11
Fluid supply	12
Fluid monitoring	13
Nozzle Installation	14–16
Tubing routing & connections.....	14
Connecting outputs	14–15
Nozzle positioning.....	16
System Operation	17–23
Starting the flow of lubricant.....	17–18
System priming	18
Lubricant output adjustment – continuous mode	19–20
Lubricant output adjustment – shot mode.....	21
Atomizing airflow adjustment	22
ML Best Practices	24
Applications	25–34
Band saws	25–26
Circular saws	27–28
Drilling	28
Milling.....	29
Routing.....	29
Broaching.....	30
Turning.....	30–31

Table of Contents

Tapping	31
Punching	32
Cut-off knives & shears	32
Die lubrication	33
Assembly operations	33
Lubricant injection prior to forming	34
Wear point and chain lubrication	34
Troubleshooting	35–38
Pump is not cycling	35
No fluid output from cycling pump	35
Fluid flows continuously without pumps cycling	35
Air bubbling in the fluid reservoir when system is operating ...	36
Pneumatic pulse generator not operating	36
Fluid is leaking from the pump	36
The pump is cycling, but the output is inconsistent	37
Outer channel of coaxial tubing contains fluid	37–38
Maintenance	39–40
Routine pump inspection	39
Replacing a pump	39
Rebuilding a pump	40
Air filters	40
Reservoir	40
Appendix A: System Spare Parts	41–42
Appendix B: Accessories	43
Appendix C: Nozzle Spare Parts	44–45
Appendix D: Part Number Scheme	46–47
Appendix E: Pulse R™ Operating Modes & Faults	48–51
Changing operation modes	48
Operation mode details	48–49
Locking the display	50
Fault indication	50–51
Appendix F: Trimming Coaxial Tubing	52
Appendix G: Enclosure Mounting Template	53

System Introduction

Thank you for purchasing a Unist Uni-Max[®] ST. This system was designed as an easy-to-use, maintenance-friendly Minimum Quantity Lubrication system that delivers consistent and reliable results.



Figure 1: Uni-Max[®] ST System

The Uni-Max[®] ST uses Unist 230 Micro Pumps™ to achieve simple and precise fluid dispensing for a broad range of manufacturing applications.

System identification & support

To identify your system, use the system label. See Appendix D to understand the configured part number. Visit unist.com/uni-max-st for more support resources.



Figure 2: System label example

System Introduction

System Function

The Uni-Max® ST delivers lubricant with one or two pneumatically-powered, positive-displacement, self-priming, 230 Micro Pumps™. The lubricant is combined with air and delivered in the form of an atomized spray.

The 230 Micro Pumps™ are actuated using either a Pulse R™ electronic pump timer or a pneumatic pulse generator, depending on the system configuration.

The 230 Micro Pumps™ feature either fixed or adjustable output

Adjustable output pumps are set by rotating the pump stroke adjustment knob, which changes the stroke. When set at “P”, these pumps operate at full stroke and are self-priming.

Fixed output pumps are permanently set at full stroke and are non-adjustable. These pumps are always self-priming.

The Uni-Max® ST will deliver lubricant when the air control valve is opened. The air control valve can be a manual slide valve, a solenoid valve, or an air pilot valve depending on system configuration. Once triggered, the system will begin to deliver lubricant in one of two modes:

- **Shot Mode** - Delivers a ‘shot’ of lubricant when actuated
- **Continuous Mode** - Delivers a continuous spray of lubricant when actuated

System output is delivered by either:

Coaxial tubing - Fluid and air are delivered through two coaxial tubes and combined at the nozzle, creating an atomized spray.

Single-line tubing - Fluid and air are combined at the system outlet port and delivered through a single tube to the nozzle.

Common System Layout

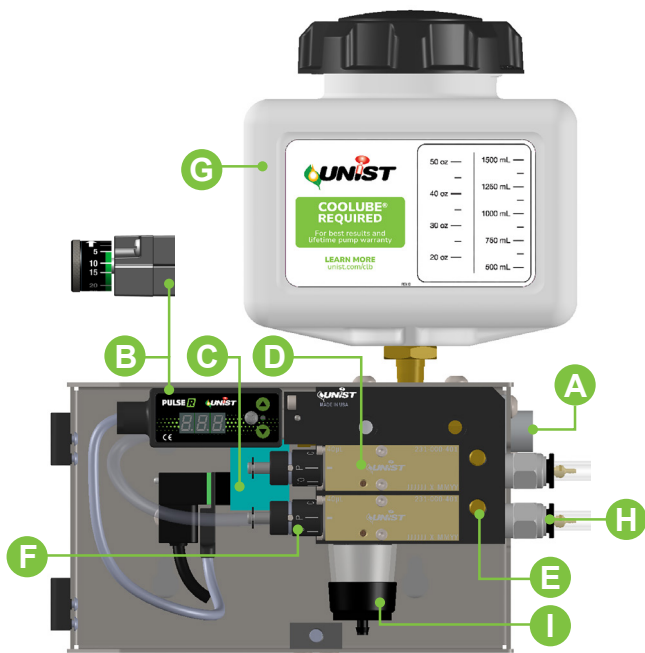

Figure 3: Common layout of system with enclosure

- A. Air inlet**
80–100 psi [5.5–7 bar] recommended
- B. Pump timer**
Pneumatic pulse generator or Pulse R™ electronic pump timer (shown)
- C. Air solenoid valve**
Used to turn the system on
- D. 230 Micro Pump™**
Precise, reliable, self-priming pump. Available in 20, 40, or 60µL output options
- E. Air metering screw**
Controls atomization airflow
- F. Pump stroke adjustment knob**
Controls fluid volume delivered per stroke.
Not present on fixed output pumps
- G. 64 oz fluid reservoir**
Additional sizes and styles available
- H. Outlet port**
Connection port for nozzles
- I. Air filter**
Ensures air is supplied according to system specifications

System Introduction

System Specifications

Supply air pressure	Clean, dry, compressed air, 80–100 psi [5.5–7 bar]			
Fluid supply	Reservoir dependent, 16–64 oz [473–1893 mL]. For systems with a pressurized fluid supply: clean, filtered fluid, 15 psi [1.0 bar] max			
Pumps	Pump Size (Output at full stroke)	20µL	40µL	60µL
	Max cycles per minute*	250	250	250
	Max output rate*	300 mL/hr	600 mL/hr	900 mL/hr
Airflow rate	0–4.7 SCFM [0–131 LPM] for each air and oil output. 1–2 SCFM [28–56 LPM] typical			
Fluid viscosity	30–5000 SUS/100°F			
Pump timer	Pneumatic pulse generator	Recommended: 5–50 pulses/min. Maximum: 200 pulses/min. (not recommended for continuous operation)		
	Pulse R™	Recommended: 5–50 Cycles per min. (Modes 1 & 2 on the Pulse R™) Maximum: 250 cycles/min.		
Operating temperature	32°–122°F [0°–50°C]			
Storage temperature	4°–158°F [-16°–70°C]			

*Fluid cycles per minute based on Coolube® 2210 and direct actuated pumps, reference Figure 5 on page 6 for other fluid viscosities

Pump Specifications

Pump components and identification

Pump bodies are marked to indicate pump size and part number. Locate these markings and identify pump components using Figure 4 below.

Adjustable Output Pumps

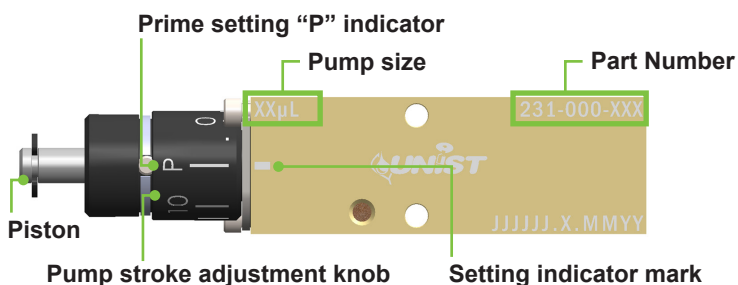

Fixed Output Pumps

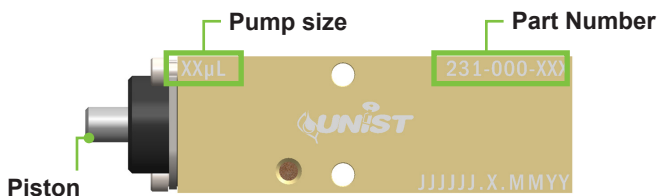

Figure 4: Pump components and identification

System Introduction

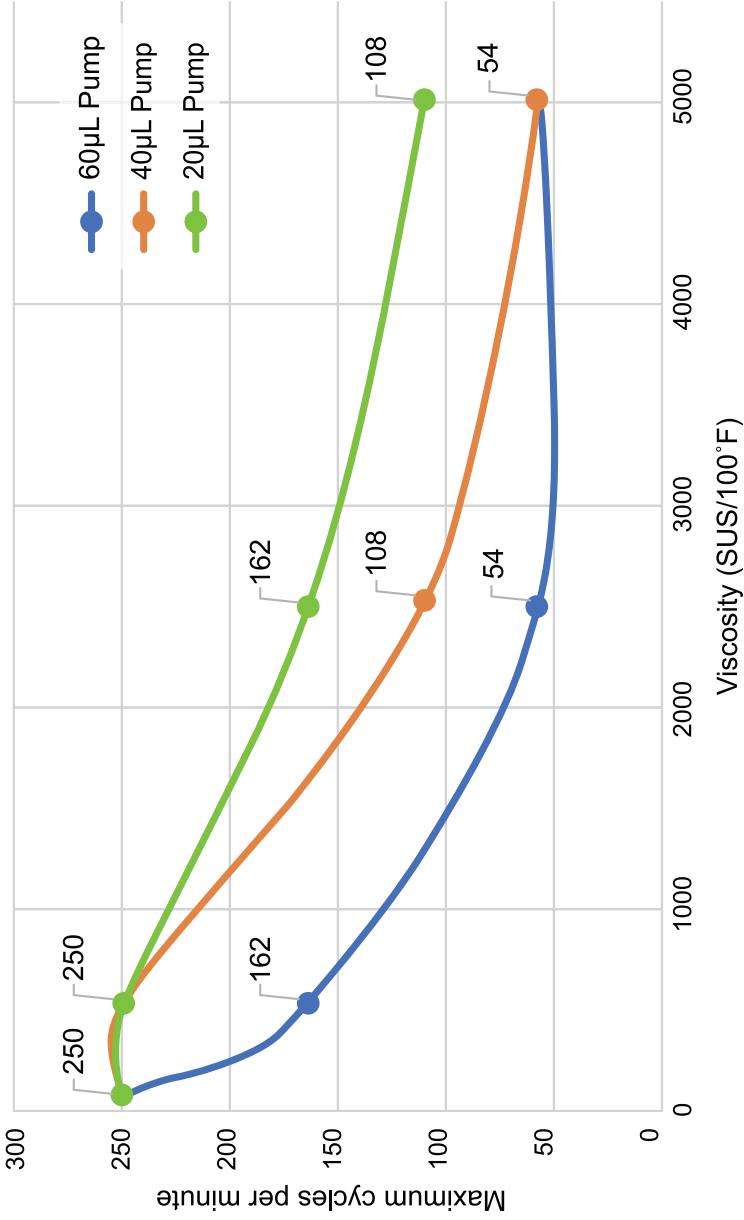

Figure 5: Maximum cycles per minute based on fluid viscosity

System Introduction

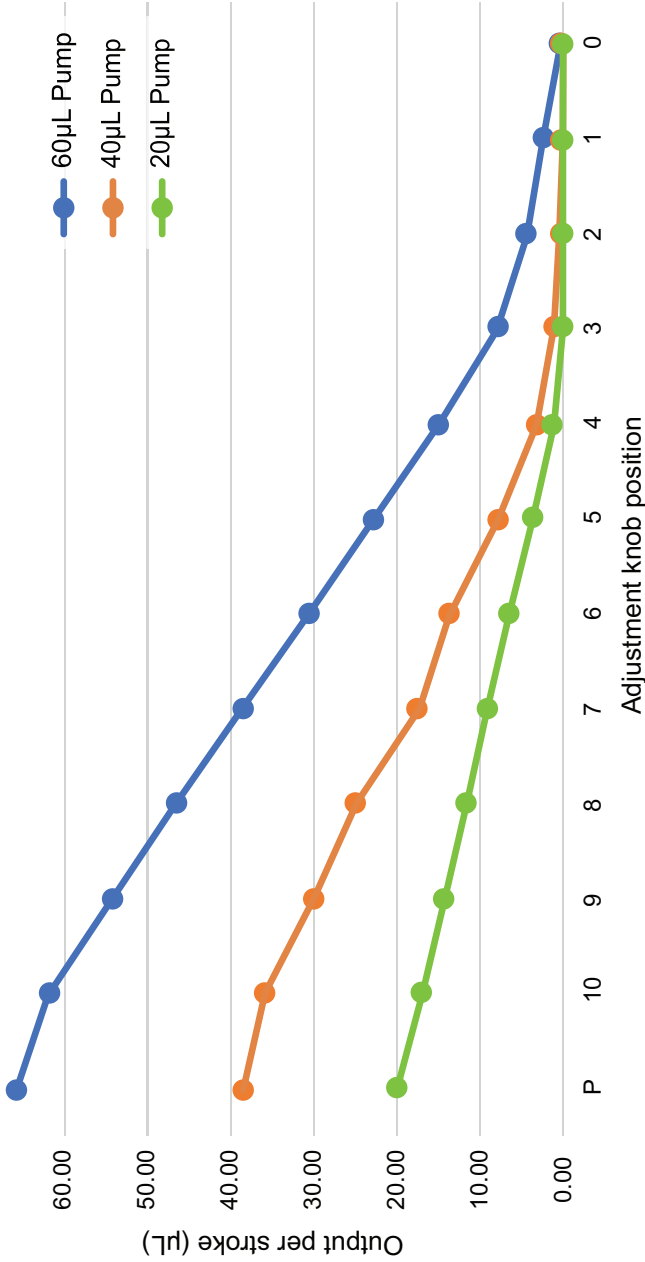

Figure 6: Effect of pump stroke adjustment knob position on fluid output

System Introduction

Solenoid Valve Specifications

To determine the valve, refer to the drawing supplied with the system or the part number scheme in Appendix D (pg. 46).

Unist Part #	Voltage	Power	Din connector size
68-1040-18-110	120 VAC	5.4 W	9.4 mm
68-1040-18-24	24 VAC	5.7 W	9.4 mm
68-1040-18-220	220 VAC	5.9 W	9.4 mm
68-1040-18-24VD	24 VDC	5.4 W	9.4 mm
68-1040-18-24VD w/Pulse R	24 VDC	17.4 W	9.4 mm
68-1040-18-12VD	12 VDC	1.8 W	9.4 mm

Note: Systems come supplied with DIN connector(s), reference Figure 12 on pg. 11 for wiring information.



Attention: Use caution when making electrical connections. Only qualified individuals should attempt to connect input power and control signals to the Uni-Max® ST. Failure to do so safely could cause damage to property and personal injury.



Attention: Ensure that power is not applied to the Uni-Max® ST while connecting solenoid inputs as this could cause personal injury or property damage.

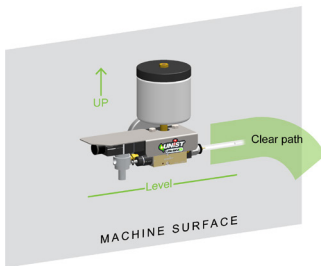

Non-enclosure system

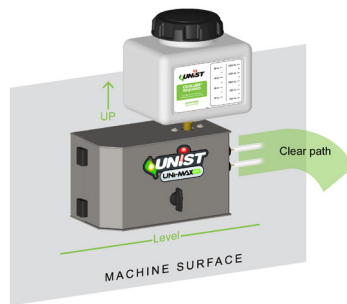

Enclosure system

Figure 7: Mounting options

Position and Mount System

Mount the system on or near the machine in an accessible location without obstructions that may pinch or kink inlet or outlet lines.

Ensure the system is level and the reservoir faces up. See Figure 7 on the previous page for details.

Mounting a system with enclosure

Mount the system with at least two fasteners or with the optional magnets (Part# 305956). Refer to Appendix G (pg. 53) for mounting template.

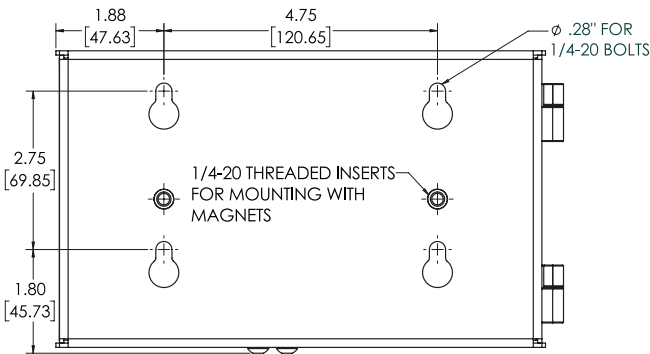

Figure 8: Mounting locations for system with enclosure

Mounting a system without enclosure

There are 3 options to mount the non-enclosure version:

- 1) Use the factory-installed magnet on the back of the system to mount the system to a vertical, magnetic surface.
- 2) Install the magnet on the bottom of the system and mount to a horizontal, magnetic surface.
- 3) Mount the system with the bolts provided.

See Figures 9 and 10 on the following page for more details.

System Installation

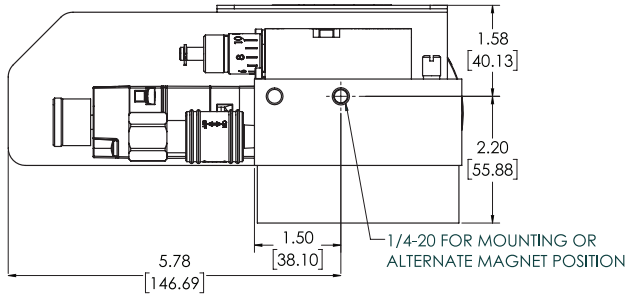

Figure 9: Alternate mounting dimensions (bottom view)

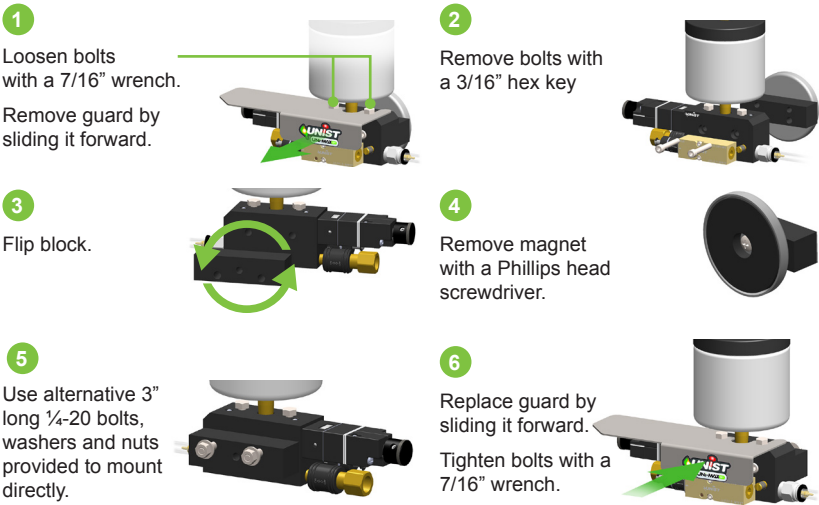

Figure 10: Mounting with through bolts



Attention: If directly mounting the system, always use two people while securing the Uni-Max® ST to its mounting surface. Failure to do so could cause personal injury.



Attention: The Uni-Max® ST must be securely mounted to a suitable mounting surface for safe operation. Use appropriate fasteners in at least two mounting positions. Failure to do so could lead to unsafe operation and personal injury.

Air supply and control

Air Supply

Attach an air supply line to the 1/4" or 1/8" NPT air inlet. If your system includes an air pilot valve, there will be an 1/8" NPT air inlet and an 1/8" NPT air inlet for the control air signal. Systems with enclosures include an air filter with a water trap.

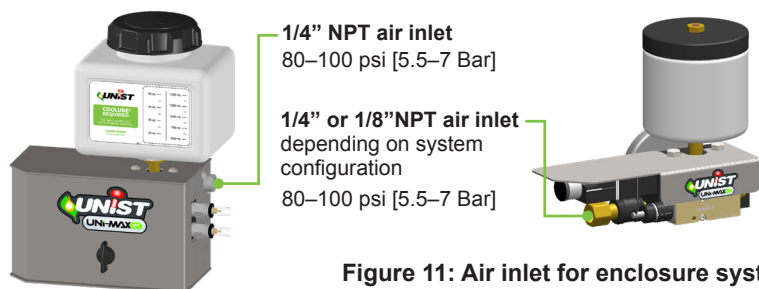

Figure 11: Air inlet for enclosure system



Attention: Use caution when connecting the system to a compressed air source. Only qualified individuals should make this connection. Failure to do so safely could cause damage to property and personal injury.

Connect control valve

The Uni-Max[®] ST can be controlled with a solenoid valve, manual slide valve or air pilot valve. If the system is to be turned on whenever the machine is operated, the solenoid valve is wired to the operation circuit on the machine. Wiring details can be found in Figure 12 below. Valve electrical requirements and cautions can be found on page 8.

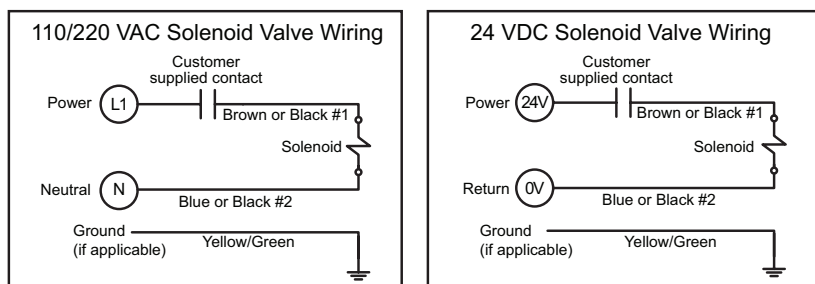

Figure 12: Control valve wiring

System Installation

Fluid Supply

Adding fluid: systems with fluid reservoir

Remove the cap, fill the reservoir with fluid, and replace the cap. Use Coolube® for the best results! Go to unist.com/clb to learn more.



Figure 13: Filling the fluid reservoir

Adding fluid: systems with pressurized fluid supply

If the system is fed with pressurized fluid from an external source and is equipped with an air trap, attach the fluid source, set the supply pressure to 10–15 psi [0.69-1.0 bar], and depress the cap until the trap is 75% full. Do this periodically to ensure the air trap maintains a consistent 10–75% full state to prevent air entering the pump(s).

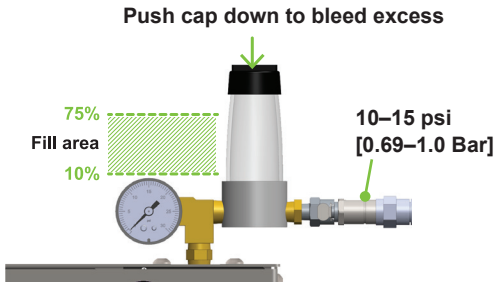

Figure 14: Bleeding air trap



Attention: Use caution while connecting to a pressurized fluid source. Fluid leaks cause hazardous slippery conditions. Only qualified individuals should attempt to make this connection.

Fluid Monitoring

Connect low-level switch (if applicable)

A low-level switch indicates that fluid needs to be added to the reservoir. If your system has a low-level switch, it can be wired to an input on the machine, an external annunciator, or another device that indicates the fluid level is low or handles the condition. See below for low-level switch wiring information.

Low-Level Switch



(2) Dots this end (NC)

- Minimum media specific gravity: 0.55
- Temperature range: -40–230°F [-40–110°C] oil, 180°F [82°C] max water
- SPST switch, normally close (NC) contact standard (closed when low), Contact can be changed to normally open (open when low) by inverting float on stem
- Max pressure: 150 psi [10 bar]
- Contact rating: 10 watts, 200 VDC max
- Switching current: 0.5 A

Maximum Resistive Load	
Voltage	Current
0–50VDC	0.2 A
120VAC	0.8 A
240VAC	0.04 A

Caution: Do not directly connect switch to inductive or other high current devices

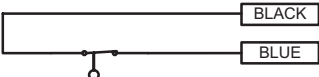

STANDARD NORMALLY CLOSED CONTACT (CLOSED WHEN LOW)

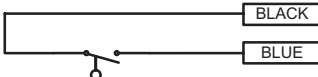

ALTERNATE NORMALLY OPEN CONTACT (OPEN WHEN LOW)

Figure 15: Low-level switch information

Low-level switch: normally open or normally closed

The low-level switch float is installed at the factory so that the switch is open when the reservoir is full and closed when the fluid level is low. If broken wire detection is desired, this can be changed by inverting the float on the stem so that the switch is closed when the reservoir is full and open when it is low.

Nozzle Installation

Tubing routing and connections

Install the nozzle(s) as close as possible to the point of application. Route the tubing back to the system and connect to the outlet port(s). Refer to the Nozzle Positioning section (pg. 16) or the Applications section (pg. 25) for more information.

Connecting outputs

Connecting single-line outputs

For systems using a single-line output, straight 1/8" tubing is supplied in conjunction with coiled 1/8" tubing. The straight tubing is used to span the distance between the system and a point near the nozzle. The coiled tubing allows for movement at the point of fluid delivery such as a moving saw armature.

Coiled tubing is designed to provide quick response time after a period of system inactivity and should always be connected to the nozzle as shown below. **In situations where tubing must be trimmed, always trim or remove the straight tubing while keeping the coiled tubing in place.** When connecting straight or coiled tubing to pumps, ensure that it is pushed firmly into the push-to-connect fitting on the pump.

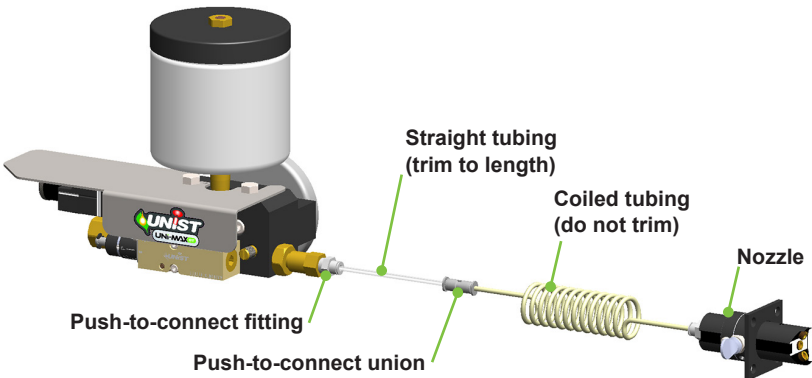

Figure 16: Single line system example

Nozzle Installation

Connecting coaxial outputs

The Uni-Max® ST uses a quick connect adapter for all nozzles with coaxial tubing. Simply push the tubing and quick connect adapter into the push-to-connect fitting until it is firmly seated. You should be able to feel a distinct click when the tubing is locked in place.

A light coat of grease (Molykote 55 or equivalent) should be applied to the O-ring at the tip of the adapter and a slight twisting motion should be used while inserting the adapter to avoid damage.

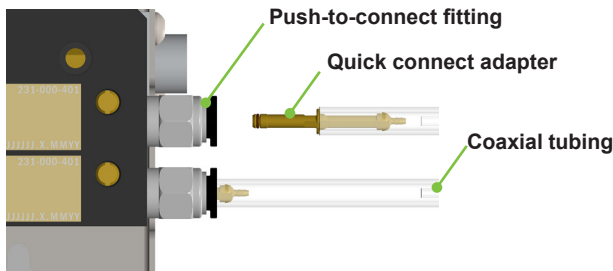

Figure 17: Inserting coaxial tubing with quick connect adapter

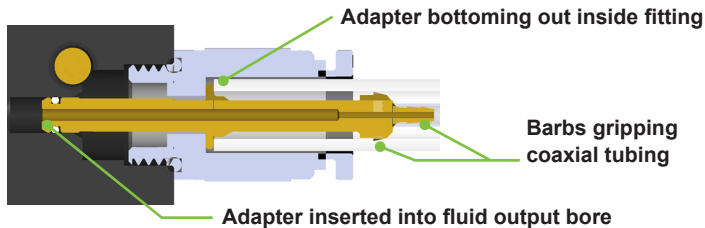

Figure 18: Cross section view of quick connect adapter properly inserted

When properly inserted, approximately 0.20" [5.1mm] of the quick connect adapter should be visible outside of the fitting. If more of the adapter body can be seen, there is a risk of fluid leaking into the air channel of the coaxial tubing.

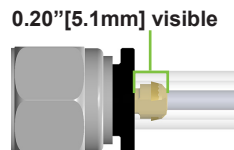

Figure 19: Proper insertion

Nozzle Installation

Trimming coaxial tubing

Extra nozzle output tubing should be coiled up and secured to the machine. If it must be shortened, follow the procedure in Appendix F on page 52.

Nozzle positioning

For more detail, refer to your specific application (pg. 25).

Single-line systems

Refer to the mounting instructions sent with the system to mount the nozzles correctly or go to unist.com/tkb and find the appropriate document for your nozzle.

Coaxial systems

Keep the nozzle as close as possible to the cutting edge, ideally within 2" [50.8 mm]. Positioning the nozzles close to the point of application minimizes the required airflow, eliminating the potential for excess mist or fogging.

There is a dead zone in lubricant coverage when a tool is perpendicular to the cut. This is because the tool itself blocks the lubricant and is generally 180 degrees from the nozzle.

Cutting should not be done in this dead zone. If working with a machine that has a nozzle with a fixed position which may cut in multiple directions, such as a mill, more than one nozzle is recommended to eliminate the dead zone.

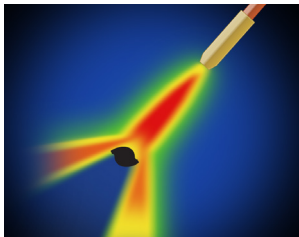

Figure 19: Dead zone with single nozzle output

Starting the flow of lubricant

The Uni-Max® ST will deliver lubricant when the air control valve is opened. The air control valve can be a manual slide valve, a solenoid valve, or an air pilot valve depending on system configuration.

Systems with a manual slide valve deliver lubricant when the valve is manually actuated.

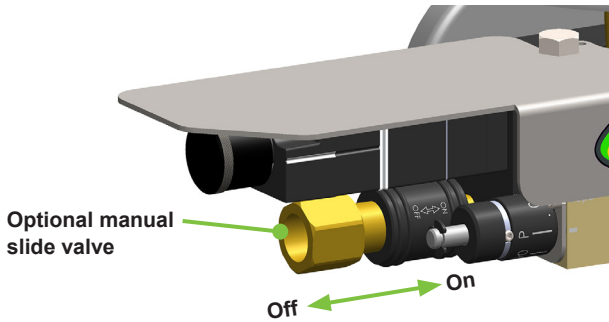

Figure 20: Manual slide valve

Systems with a solenoid valve deliver lubricant when the correct electrical voltage is applied. If the system is supplied with a Pulse R™, the solenoid valve will supply power to the Pulse R™.

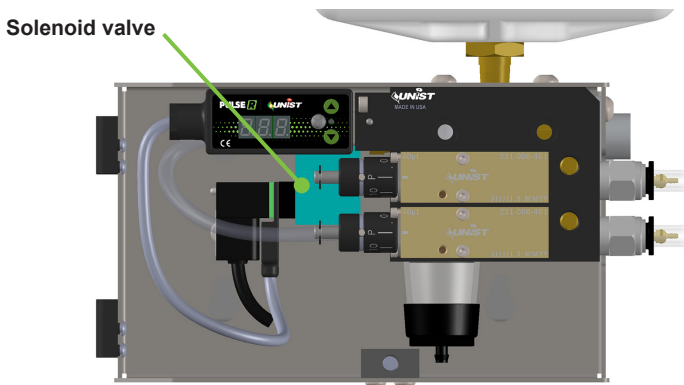

Figure 21: Solenoid valve

System Operation

Systems with an air pilot valve deliver lubricant when an air signal is received.

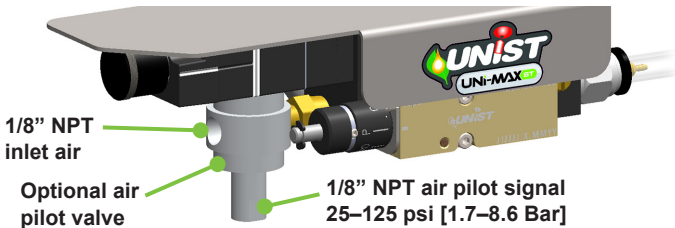

Figure 22: Pneumatic air pilot valve



Attention: Ensure air pressure is not present when connecting the air pilot signal to the Uni-Max® ST air pilot valve as this could cause personal injury or property damage.

System priming

Uni-Max® ST pumps are self-priming and will draw fluid even if there is air present. Priming the pumps may be necessary at installation or if the reservoir runs dry.

Priming an adjustable output pump

- Set the pump stroke adjustment knob to the “P” (prime) setting.
- Activate the system and prime the pump(s) until the nozzles spray consistently.

Priming a fixed output pump

- Fixed output pumps will prime automatically.
- Activate the system and prime the pump(s) until the nozzles spray consistently.

Note: To prime quickly (useful for long tubing lengths), temporarily increase the cycle rate or number of shots while priming.



Attention: Ensure all people are clear from the area of the system’s nozzles when operating the outputs manually. Failure to do so could result in personal injury.

Lubricant output adjustment – continuous mode

Note: The Uni-Max® ST is factory preconfigured to operate in either continuous or shot mode. The mode cannot be changed.

When adjusting lubricant output, we recommend setting the pump at full stroke (“P” setting) and increasing or decreasing the pump cycle rate with either the Pulse R™ or the pneumatic pulse generator.

If more precision is needed, adjust the pump stroke (does not apply to fixed output pumps).

Pulse R

The pump cycle rate can be increased or decreased by pressing the UP or DOWN arrows. Reference Appendix E (pg. 48) for more information.

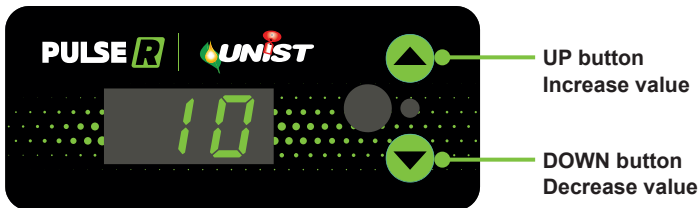

Figure 23: Pulse R™ electronic timer

Pneumatic pulse generators

Turn the knob clockwise or counterclockwise to decrease or increase the frequency respectively. The number on the dial will line up with the alignment notch on the mounting block for an approximation of cycles per minute.

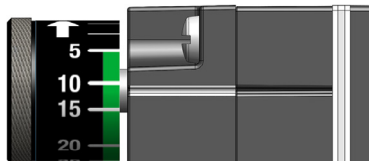

Figure 24: Pneumatic pulse generator adjustment knob

System Operation

Pump stroke

Use the pump stroke adjustment knob to change the pump stroke.

“P” indicates full stroke and self-priming functionality. “O” indicates no output. Refer to Figure 6 on page 7 for pump output details.



Figure 25: Pump stroke adjustment knob in prime position (left) and in the off position (right)

Lubricant output adjustment – shot mode

Note: The Uni-Max® ST is factory preconfigured to operate in either continuous or shot mode. The mode cannot be changed.

When adjusting lubricant output, we recommend changing the stroke count. If more precision is needed, adjust the pump stroke (this cannot be done with a fixed output pump).

Stroke count – shot mode

The stroke count on the Pulse R™ can be changed by pressing the UP or DOWN buttons to increase or decrease the number of pump strokes per shot respectively. The max number of shots for a Pulse R™ is 99 shots per input. Reference Appendix E (pg. 48) for more information.

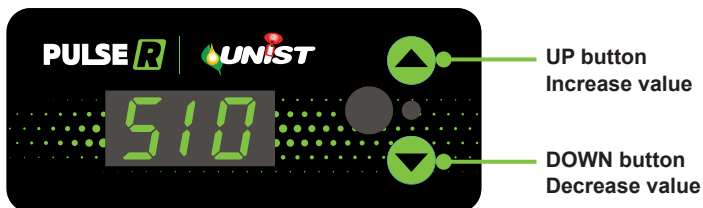
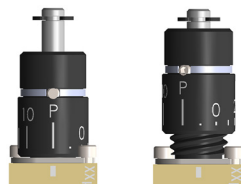

Figure 26: Pulse R™ electronic timer

Pump stroke

Use the pump stroke adjustment knob to change the pump stroke. “P” indicates full stroke and self-priming functionality. “0” indicates no output. Refer to Figure 6 on page 7 for pump output details.

Figure 27: Pump stroke adjustment knob in prime position (left) and in the off position (right)



System Operation

Atomizing airflow adjustment

The air metering screw will adjust how fine of a spray is generated at the nozzle. Too little airflow will result in a pulsating and spitting spray. Too much airflow will create a fog of very fine mist!

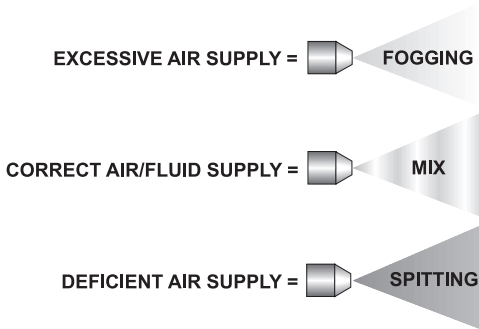

Figure 28: Adjusting atomizing airflow

Rotate the air metering screw clockwise until it is fully seated, then:

- Back screw off 1/4–1/2 turn (45° – 90°) for single-line systems (1/8" tubing).
- Back screw off 1/2–3/4 turn (180° – 270°) for coaxial systems (3/8" tubing with 1/8" inner tubing).

Excess airflow will cause undesirable fogging!

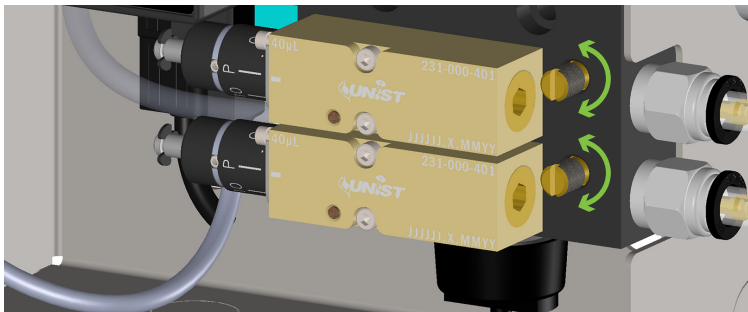

Figure 29: Use metering screw to adjust airflow

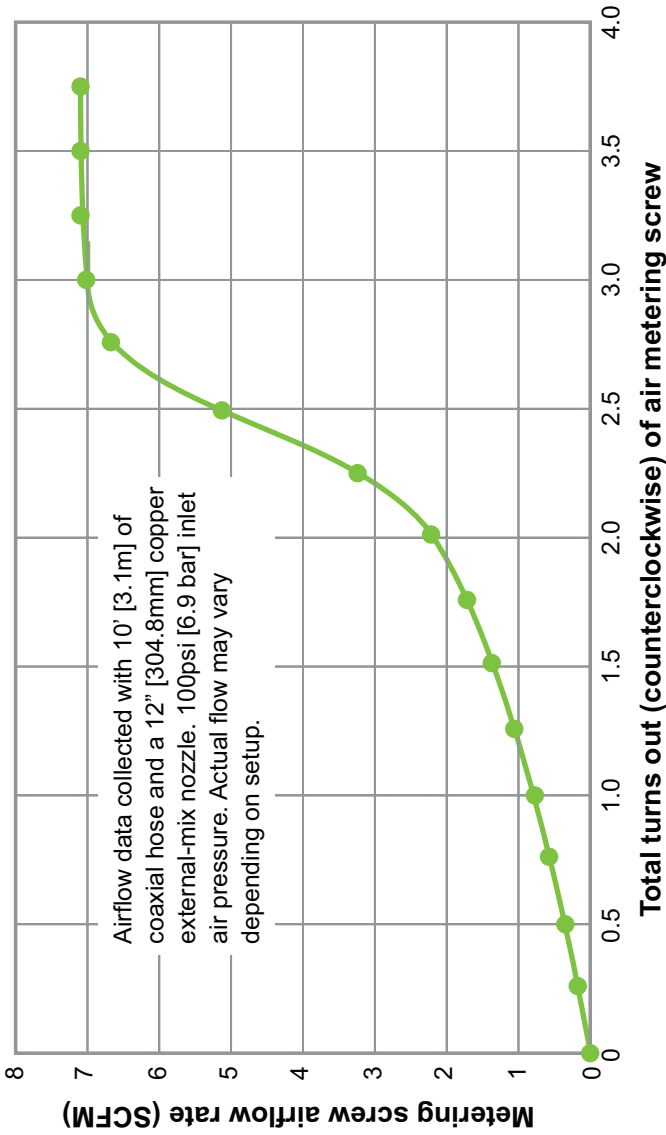

Figure 30: Approximate air metering screw airflow rate

MQL Best Practices

- Use only a quality lubricant formulated for Minimum Quantity Lubrication such as Unist Coolube®. Non-MQL metalworking fluids do not offer the proper lubricity or flash point for use in MQL and any biocides they contain can become airborne causing a safety issue.



Note: For a lifetime warranty on your Uni-Max® ST pumps, use Coolube® lubricant exclusively.

- If chips are sticking to the tool or lubricant is puddling, you are applying excess lubricant.
- If a built-up edge is forming and material is welding to the tool, there is too much heat. Adjust the fluid output or vary machine feeds and speeds. Replace tool if necessary.
- The fluid output should be virtually invisible. If you are able to see fluid, you are applying excess lubricant and will likely see undesirable fogging. To quickly verify fluid output, place a piece of cardboard in front of the nozzle.
- Saw blades should remain relatively cool. If your blade is too warm, increase fluid output and/or decrease feed rate.
- If you have smoke forming, you are over applying the lubricant and the excess is burning off.
- Using too much lubricant defeats MQL's core concept of a thin lubricant barrier between the tool or blade and the workpiece.

Band Saws

Combine the Uni-Max® ST with one or more of Unist's specialized sawing nozzles to precisely deliver the correct amount of Coolube® lubricant directly to the critical areas of the saw blade and guides. Unist recommends the following settings as a starting point for band saw applications.

Pump cycles per minute	Stroke length	Air metering screw settings	Output mode
10 - 25	Full to 1/2	1/4–1/2 Turns open	Continuous

Bat Nozzle - mounted through the blade guard (all band saw applications)

The Unist Bat Nozzle provides coverage with three outputs aimed at the blade sides and the gullet of the teeth. Available in 1.6" [40.6 mm], 3" [76.2 mm], and 7" [177.8 mm] lengths to fit any size blade guard.

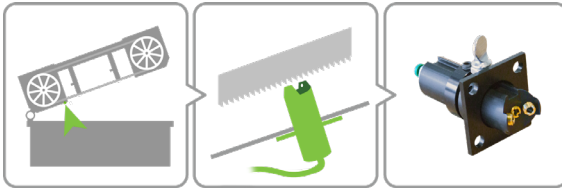

Band Saw Blade Nozzle - mounted to guides or guard with mounting kit (horizontal band saw applications)

The Band Saw Blade (BSB) Nozzle provides alternative mounting options and delivers an ideal spray pattern for horizontal band saw blade lubrication.

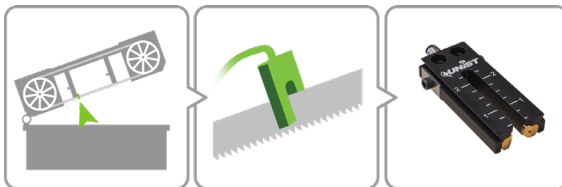

Applications

Band Saw Guide Nozzle - mounted to the blade guide (horizontal band saw applications)

When blade guide lubrication is required, the Band Saw Guide (BSG) Nozzle will lubricate both sides of the blade to help minimize friction. The BSG Nozzle can be mounted directly to a guide block, to the BSB Nozzle, or installed with the provided mounting kit. When paired with a BSB Nozzle, lubrication for both the cutting edge and the sides of the blade is provided.

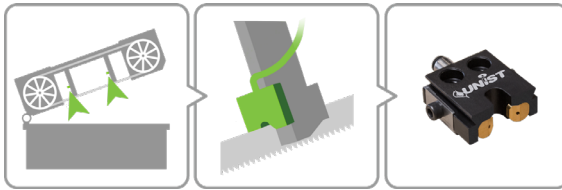

Circular Saws

The Uni-Max® ST precisely delivers the optimal amount of Coolube® directly to critical areas of the saw blade. Unist recommends the following settings as a starting point for circular saw applications.

Pump cycles per minute	Stroke length	Air metering screw settings	Output mode
10 - 25	Full to 1/2	1/4–1/2 Turns open	Continuous

Bat Nozzle - mounted through the blade guard (circular saws equipped with guard)

The Bat Nozzle provides coverage with three outputs aimed at the blade and gullet of the teeth. 1.6" [40.6 mm], 3" [76.2 mm], and 7" [177.8 mm] lengths available to fit any size blade guard.

For applications where the Bat Nozzle cannot easily be mounted or will not fit, coaxial nozzles or a splitter nozzle may be used.

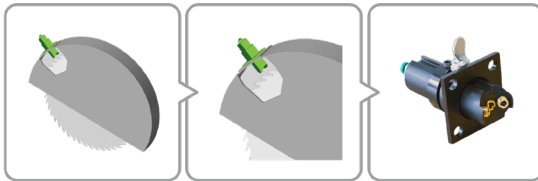

Coaxial nozzles - directed at the saw blade

Use two coaxial nozzles for applications where a Bat Nozzle cannot easily be mounted or will not fit. The nozzles should be positioned to spray the sides of the blade and into the gullet of the teeth.

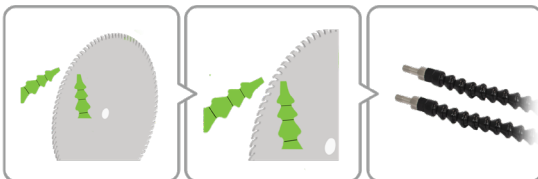

Applications

Splitter nozzle - directed at the saw blade

For applications where neither a Bat Nozzle nor coaxial nozzles will fit, a compact splitter nozzle could be the best solution. The nozzles should be aimed to spray the sides of the blade and into the gullet of the teeth.

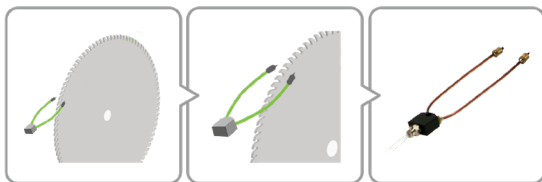

Drilling

The Uni-Max[®] ST reduces drill wear and improves hole quality. Unist recommends the following settings as a starting point for drilling applications.

Pump cycles per minute	Stroke length	Air metering screw settings	Output mode
5–20	Full to 1/2	1/4–3/4 Turns open	Continuous

Coaxial nozzle - directed at the drill

A single coaxial nozzle directed at the interface between the cutting edge of the drill and the workpiece at a downward angle is recommended. Pecking may be necessary on deep holes to facilitate reapplication of lubricant.

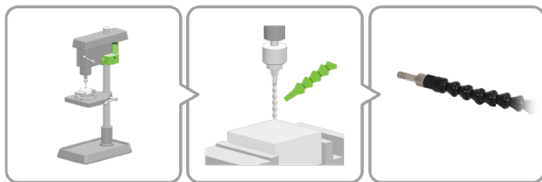

Milling

The Uni-Max® ST increases tool life and improves surface finishes. Unist recommends the following settings as a starting point for milling applications.

Pump cycles per minute	Stroke length	Air metering screw settings	Output mode
10–25	Full to 1/2	1/4–3/4 Turns open	Continuous

Coaxial nozzles - directed at the milling cutter

Two coaxial nozzles positioned 180° apart and directed toward both sides of the cutting tool are recommended for the best results.

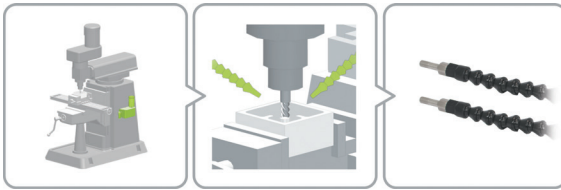

Routing

The Uni-Max® ST increases tool life without the mess associated with flood coolant. Unist recommends the following settings as a starting point for routing applications.

Pump cycles per minute	Stroke length	Air metering screw settings	Output mode
10–25	Full to 1/2	1/4–3/4 Turns open	Continuous

Coaxial nozzles - directed at router cutter

Two coaxial nozzles positioned 180° apart and directed toward both sides of the cutter are recommended for optimal results.

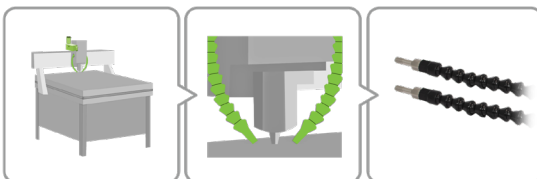

Applications

Broaching

The Uni-Max® ST improves tool life when combined with compressed air blow-off to clear chips. Unist recommends the following settings as a starting point for broaching applications.

Pump cycles per minute	Stroke length	Air metering screw settings	Output mode
10–25	Full to 1/2	1/8–1/2 Turns open	Continuous

Coaxial nozzles - directed at the broach

Two coaxial nozzles positioned 180° apart at a downward angle directed perpendicular to the broach are recommended.

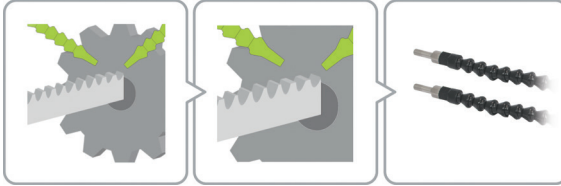

Turning

The Uni-Max® ST improves tool life for CNC and manual lathes without fluid mess. Unist recommends the following settings as a starting point for turning applications.

Pump cycles per minute	Stroke length	Air metering screw settings	Output mode
10–25	Full to 1/2	1/4–3/4 Turns open	Continuous

Coaxial nozzles - directed at back side of the cutting tool (external spray on a manual lathe)

Optimum lubrication will be achieved by directing a single coaxial nozzle at the back side (non-cutting edge) of the cutting insert.



Through the turret - directed at cutting tool (external spray or through-the-tool CNC turning center)

The Uni-Max® ST can deliver metered lubricant through a CNC turning center's coolant ports. The ability to apply MQL in this fashion depends on the design of the machine turret.

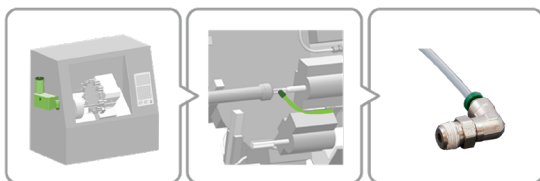

Tapping

The Uni-Max® ST reduces tap wear and improves thread quality. It can be used with both cutting and forming taps. Shot mode works well for most tapping applications. For large diameter or deep tapping, continuous mode may provide better results (refer to *Drilling* section on page 28 for recommended settings).

Pump cycles per tool operation	Stroke length	Air metering screw settings	Output mode
1-5	Full to 1/4	1/4-1/2 Turns open	Shot

Coaxial nozzle - directed at the tap

A single coaxial nozzle directed at the interface between the tap and the workpiece at a downward angle is recommended. Pecking may be necessary for reapplication of lubricant on deep tapped holes.

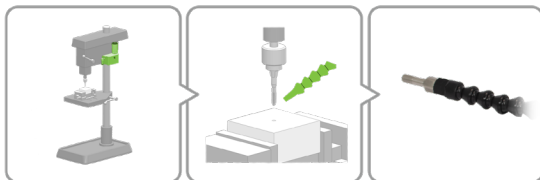

Applications

Punching

The Uni-Max® ST improves finishes and increases punch life significantly for any type of punching operation including turret presses. Unist recommends the following settings as a starting point for a punching applications.

Pump cycles per tool operation	Stroke length	Air metering screw settings	Output mode
1–2	Full to 1/2	1/4–1/2 Turns open	Shot

Coaxial nozzles - directed at the punch

Use two coaxial nozzles positioned 180° from each other and pointed at the punch's cutting edge.

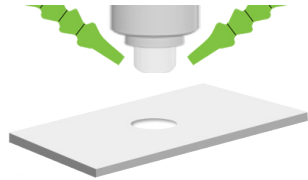

Cut-off knives & shears

Apply a small amount of Coolube® to knives and shears to produce cleaner cuts and increase tool life. Unist recommends the following settings as a starting point for cut-off knives & shear applications.

Pump cycles per tool operation	Stroke length	Air metering screw settings	Output mode
1–2	Full to 1/2	1/4–1/2 Turns open	Shot

Coaxial nozzle - directed at the cutting edge

A single coaxial nozzle directed at the cutting edge of the knife or shear.

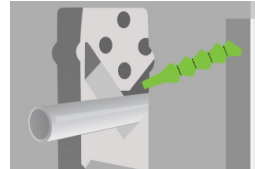

Die lubrication

A Uni-Max® ST is ideal when only a small amount of in-die lubrication is needed. This system lubricates punches, forming dies, or in-die taps. Unist recommends the following settings as a starting point for die lubrication.

Pump cycles per tool operation	Stroke length	Air metering screw settings	Output mode
1–5	Full to 1/2	1/4–3/4 Turns open	Shot

Coaxial nozzle(s) - directed at tooling

One or two coaxial nozzle(s) directed at the area requiring lubrication.

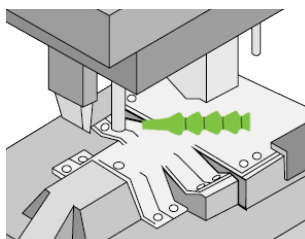

Assembly operations

The Uni-Max® ST can be used to lubricate seals or other components prior to assembly. Unist recommends the following settings as a starting point for assembly lubrication.

Pump cycles per tool operation	Stroke length	Air metering screw settings	Output mode
1–2	Full to 1/4	1/4–1/2 Turns open	Shot

Coaxial nozzle(s) - directed at assembly point

One or two coaxial nozzle(s) directed at the area requiring lubrication.

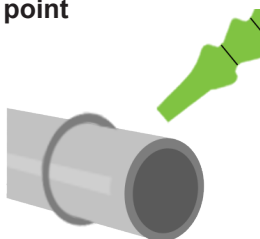

Applications

Lubricant injection prior to forming

The Uni-Max® ST can lubricate the inside of tube stock before a secondary operation. Unist recommends the following settings as a starting point for lubricant injection.

Pump cycles per minute	Stroke length	Air metering screw settings	Output mode
10–25	Full to 1/2	1/4–3/4 Turns open	Continuous

Coaxial nozzle(s) - directed at tube

One or two coaxial nozzles directed at the inside diameter of the tube.

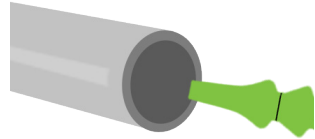

Wear point and chain lubrication

Uni-Max® ST makes lubricating cams, bearings, chains, or other wear points a simple process. Unist recommends the following settings as a starting point for wear point and chain lubrication.

Pump cycles per tool operation	Stroke length	Air metering screw settings	Output mode
As required	1/2 to 1/4	1/4–1/2 Turns open	Shot or Continuous

Coaxial nozzle - directed at wear point

A single coaxial nozzle directed at the required area of lubrication.

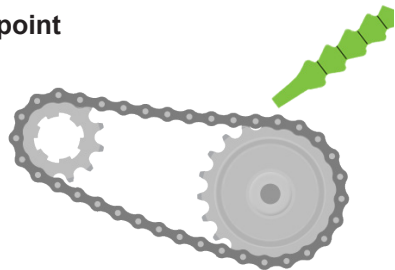



Attention: While troubleshooting, it may be necessary to access the electrical solenoid on the Uni-Max® ST. Only qualified individuals should perform such work and control power to the Uni-Max® ST should be turned off when accessing this enclosure.

Pump is not cycling

- Confirm the Pulse R™ or pulse generator is not set to 0.
- Confirm the incoming air pressure is between 80–100 psi [5.5–7 bar].
- Confirm the control valve is open and allows airflow to the system.
- If using a pneumatic pulse generator, inspect the inlet screen for debris and clean if necessary. See Figure 31 (pg. 36).

No fluid output from cycling pump

- Confirm pump is cycling by visually confirming piston movement.
- Ensure the pump stroke adjustment knob is not set to 0.
- Confirm the reservoir contains adequate fluid and the filter screen is clean.
- Confirm the pump is primed by cycling it with the pump stroke adjustment knob turned to “P.”
- Replace or rebuild the pump. It is suggested to keep a spare pump to minimize downtime.

Fluid flows continuously without pumps cycling

- If using a pressurized fluid supply, ensure fluid pressure is < 15psi [1 bar].

Troubleshooting

Air bubbling in the fluid reservoir when system is operating

- Replace or rebuild the pump. Internal components may have failed or become contaminated with debris.

Pneumatic pulse generator not operating

- Remove the pneumatic pulse generator and check the air inlet screen for debris. If no debris is found, replace the pneumatic pulse generator. See illustration below for location of the air inlet screen.

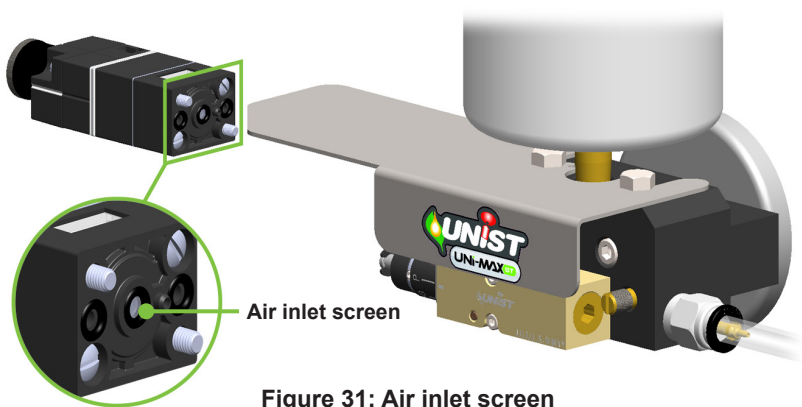

Figure 31: Air inlet screen

Fluid is leaking from the pump

- Replace or rebuild the pump. Internal components may have failed or become contaminated with debris.

The pump is cycling, but the output is inconsistent

- Check for a kink or break in nozzle tubing.
- Confirm the reservoir contains adequate fluid and the filter screen is clean.
- For coaxial nozzles, confirm the internal fluid tubing is properly seated on both the quick connect adapter and the nozzle splicer.
- Confirm the pump cycle rate has not exceeded the max cycle rate for the given fluid viscosity, see Figure 5 (pg. 6).
- Replace or rebuild the pump. Internal components may have failed or become contaminated with debris.

Outer channel of coaxial tubing contains fluid

In some instances, fluid can accumulate in the outer channel of coaxial tubing. This is usually caused when atomizing airflow is insufficient and/or the fluid outlet line is positioned lower than the nozzle coupler block. The problem can be alleviated by:

- Increasing the atomizing airflow.
- Raising the fluid line so the fluid flows down into, and eventually out of, the nozzle.
- Ensuring that the quick connect adapter is fully inserted into the fluid outlet. See page 15 for more detail.
- Ensuring the inner-channel tubing is installed properly on the internal fitting barb. See Figure 18 (pg. 15) for more detail.
- Removing the quick connect adapter from the push-to-connect fitting and inspecting the O-ring on the tip of the adapter for any damage. Replace the quick connect adapter if defective (Part# 304902-V). See Figure 18 (pg.15) for more detail.

(Continued next page)

Troubleshooting

- Mounting the nozzle coupler block at an angle so fluid flows down into, and eventually out of, the nozzle. See Figure 32 below for an example of proper nozzle coupler block mounting.

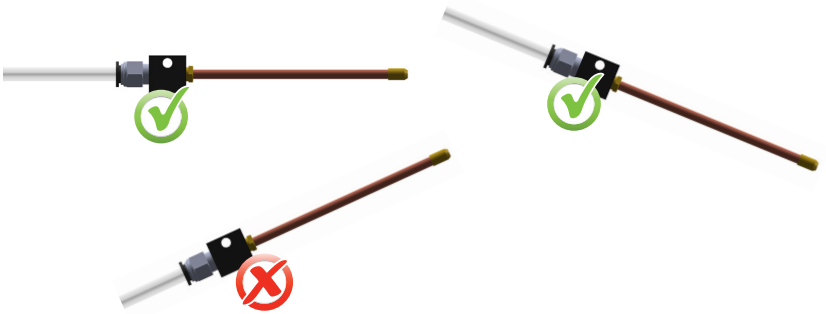

Figure 32: Proper nozzle positioning

Refer to the following instructions for common maintenance tasks:

Routine pump inspection

Routine inspection and maintenance of the system's 230 Micro Pumps™ is critical to ensure smooth operation. Check for proper operation and output of the pump(s) every 6 months or 2.5 million cycles. Pumps that do not stroke smoothly or fail to output the proper amount of fluid should be rebuilt or replaced.

Replacing a pump

1. Drain the fluid reservoir.
2. Remove the two pump-mounting bolts on the front of the pump using a 7/64 hex key.
3. The middle hole behind the pump can be temporarily plugged with one of the pump-mounting bolts to minimize fluid leakage. See Figure 34 below for more detail.
4. Ensure all three O-rings are installed in the manifold and are not cut or damaged.
5. Replace with a new pump and tighten bolts to 6 in-lbs torque.
6. Fully prime the pump. Refer to *System Priming* on page 18 for details.

Remove bolts with a 7/64 hex key

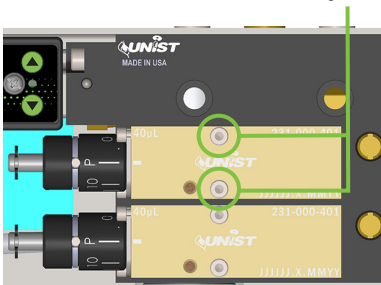

Figure 33: Removing a pump

Plug fluid inlet hole with mounting bolt

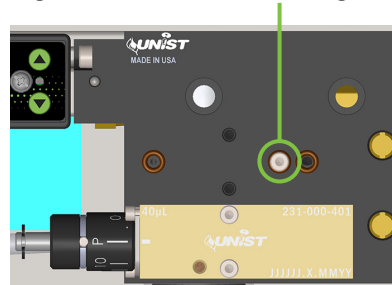

Figure 34: Plug fluid inlet hole

Maintenance

Rebuilding a pump

Pumps are easily rebuilt, but to minimize downtime, Unist recommends keeping a spare pump on hand so the system can continue operation while the pump is rebuilt. Pump rebuild kits include all wear parts, seals, and instructions. Refer to Appendix A (pg. 41) for part numbers.

Air filters

The air filter will need to be checked periodically for dirt, debris, or water. If there is water in the air filter, hold a container below the air filter and press up on the black cap to drain the water. If the filter is visibly dirty, turn off the incoming air and remove the valve and filter assembly (located behind pumps). Finally, replace the filter element or filter assembly.

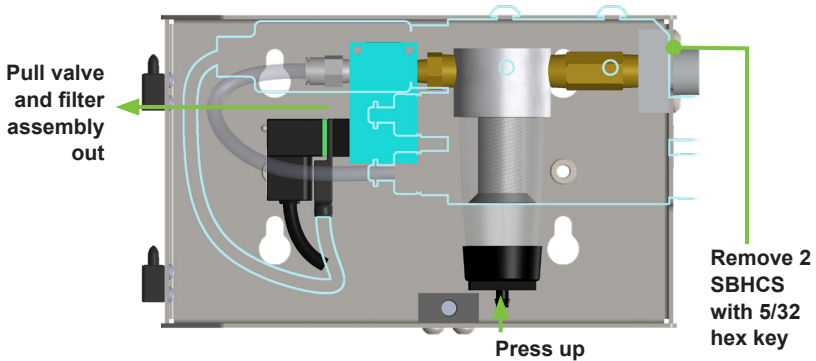

Figure 35: Purging water from the air filter trap

Fluid reservoir

There is a strainer on the inside of all fluid reservoirs. When refilling the reservoir, remove any dirt or debris that may be present.

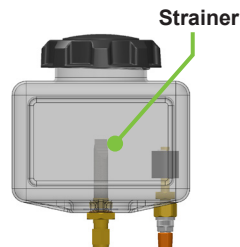
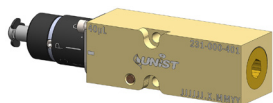

Figure 36: Fluid reservoir cleaning

Appendix A: System Spare Parts

Adjustable Output Pump



Size	Pump #	Rebuild Kit
20 μ L	231-000-201	231-000-201R
40 μ L	231-000-401	231-000-401R
60 μ L	231-000-601	231-000-601R

Fixed Output Pump



Size	Pump #	Rebuild Kit
20 μ L	231-000-211	231-000-211R
40 μ L	231-000-411	231-000-411R
60 μ L	231-000-611	231-000-611R

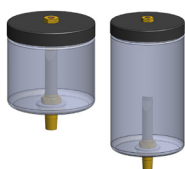

Reservoir,
HDPE
69-459-PE (16 oz)
69-460 (32 oz)

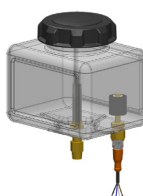

Reservoir,
64oz., HDPE
301313 (with low level)
301311 (without low level)



Pulse R
with Wafer,
305326-C1-ST
(Continuous Mode)
305326-C3-ST
(Shot Mode)

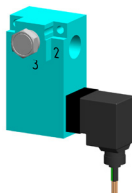

Air Inlet
Solenoid Valve
See specifications pg. 8

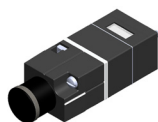

Pneumatic
Pulse
Generator
301930



Air Trap Assembly
306022



Air Pilot Valve
1/8" NPT
68-1030-18



Air Filter 1/4" NPT
69-459

Appendix A: System Spare Parts

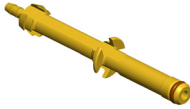

Quick Connect Adapter
304902-V (includes O-ring)



Pump Mounting O-rings
2-007-V884-75



Slide Valve
Standard 1/4" NPT
69-5506



Slide Valve
1/8" NPT
305856



Replacement Door with Latch
306009-A



Replacement Door with Key
Lock 306009-B



Chip Guard
306006

Appendix B: Accessories

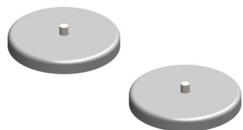

Enclosure Magnet Mounting Kit
305956



Articulating Arm
for Nozzle Mounting
306005

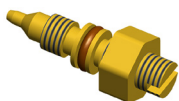

Metering Screw with Jam Nut
94-6202-J



Enclosure Key Lock
306008

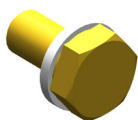

Full Flow Metering Screw
305193

Appendix C: Nozzle Spare Parts

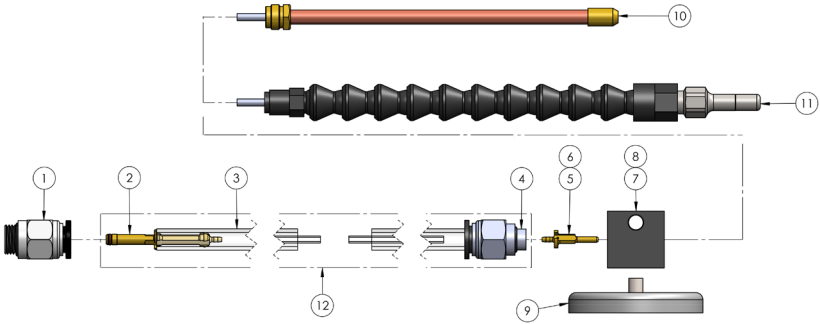

12	COAX HOSE ASSEMBLY, QUICK CONNECT, VITON SEAL, YY' LONG	305374-Q1-YY
11	NOZZLE ASSEMBLY, XX" PLASTIC, EXT. MIX W/ STAINLESS STEEL TIP	6121-P-XXP-SS
10	NOZZLE ASSEMBLY, XX" COPPER EXTERNAL MIX	6121-P-XXSR
9	MAGNET, NOZZLE BLOCK	60-6340-22
8	NOZZLE COUPLER BLOCK, 1/8 NPT, 1/8 NPT	6110-3
7	NOZZLE COUPLER BLOCK, 1/8 NPT, 7/16-20	6110
6	SPLICER, CAPILLARY TUBING, W/O HOLE	302116
5	SPLICER, CAPILLARY TUBING, W/HOLE	302116-H
4	PUSH IN FITTING, 3/8" X 1/8" UNIVERSAL PIPE THREAD	301875
3	CO-AX HOSE WITHOUT FITTINGS, 6100 & 71-2050, PER FOOT	6124
2	SPLICER, CAPILLARY, QUICK CONNECT COAX W/VITON SEAL	304902-V
1	PTC, NP BRASS, STRAIGHT, 1/4" UNIVERSAL X 3/8" OD	PTC-1S-U02-38
ITEM NO.	DESCRIPTION	PART NUMBER

Figure 37: Coaxial nozzle spare parts

Appendix C: Nozzle Spare Parts

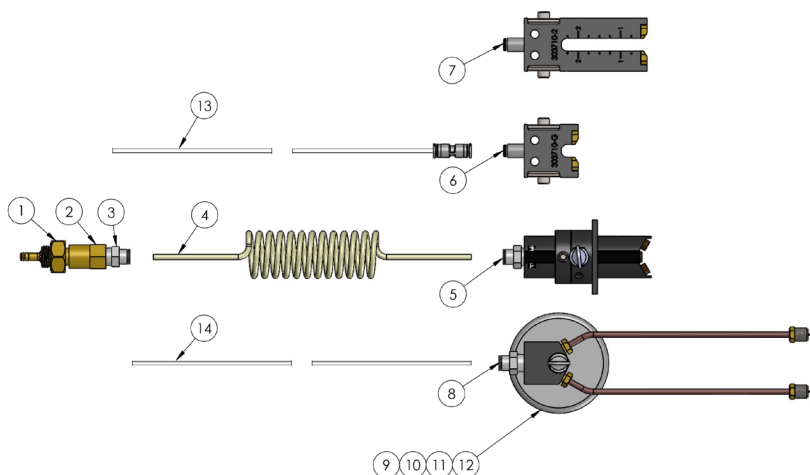

14	TUBING, 1/8" OD NYLON, PER FOOT	71-2050
13	TUBING EXTENSION KIT, SAW NOZZLE	302637
12	MAGNET, NOZZLE BLOCK	60-6340-22
11	NUT, COUPLING, HEX, 1/4-20 UNC X 7/8" LG	305482
10	THUMB SCREW, 1/4-20 X 1" LG	1420-1THS
9	LOCKWASHER 1/4"	14-SPLOCK
8	SPLITTER NOZZLE, 1/8" OD COPPER, XX" LG.	2032-XXSR
7	NOZZLE ASSEMBLY, BAND SAW BLADE, X", WITH MOUNTING KIT	303710-X-A
6	NOZZLE ASSEMBLY, BAND SAW GUIDE, WITH MOUNTING KIT	303710-G-A
5	NOZZLE, SAW, X" BAT, INCLUDES MOUNTING BRACKET	3S-X
4	TUBING, NYLON CAPILLARY, COILED, 1/8 OD, 10' LG.	71-2050-10C
3	PTC, NP BRASS, STRAIGHT, 1/8" NPT X 1/8" OD	9303-016
2	CHECK VALVE, 1/8 NPT, MALE TO FEMALE	210-2M2F-F
1	1/4-28 NPS MALE TO 1/8 NPT FEMALE BUSHING W/ SEAL	305627
ITEM NO.	DESCRIPTION	PART NUMBER

Figure 38: Single-line nozzle spare parts

Appendix D: Part Number Scheme

System part number scheme

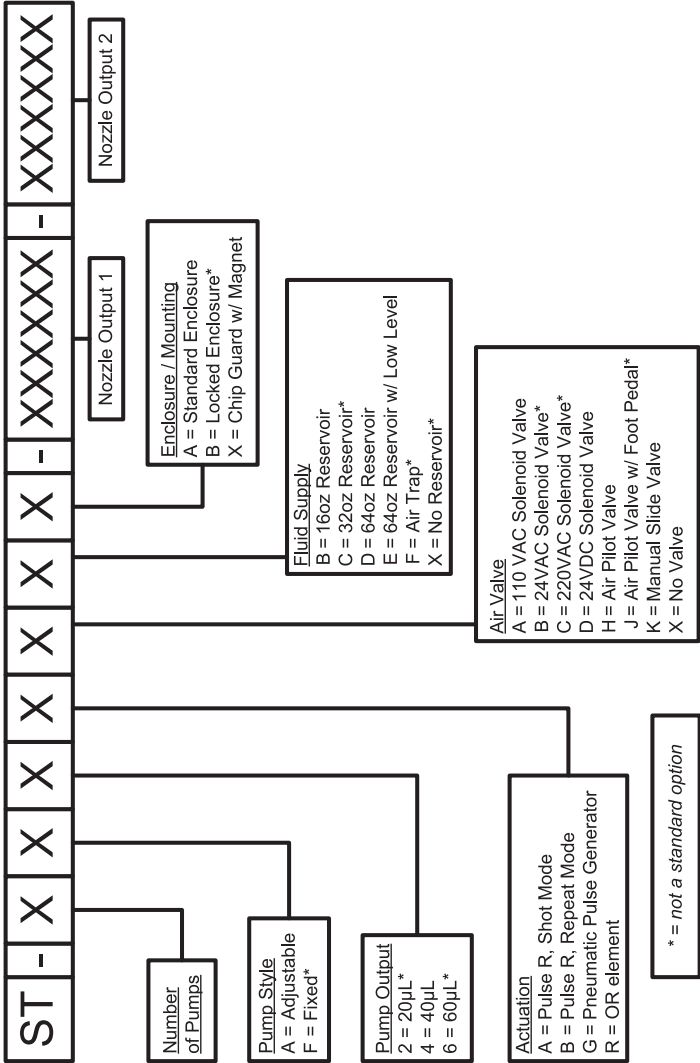

Appendix D: Part Number Scheme

Nozzle output part number scheme

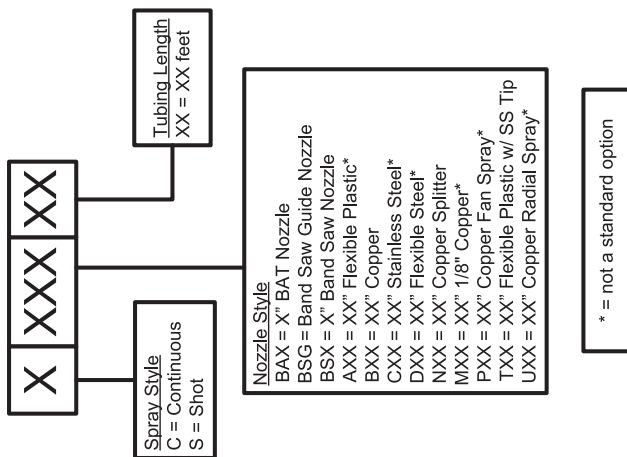

Appendix E: Pulse R™ Operating Modes and Faults

Changing Operation Modes

The Pulse R™ is configured for your desired operating mode at the factory and should only be changed if directed to do so by a Unist representative. To change modes, simultaneously press and hold both the UP and DOWN buttons while turning on power to the Pulse R™. Continue holding both the UP and DOWN buttons for 2 seconds until the mode number with a period before it is displayed.



Figure 39: Mode selection (mode 1 displayed)

Use the UP and DOWN buttons to select the desired mode. To confirm selection, press and hold the UP and DOWN buttons for 2 seconds. After 2 seconds, the display will show the setpoint for the selected mode.

When changing to mode 3, the system will display the shot delivery rate (in cycles/min.) after pressing and holding the UP and DOWN buttons for 2 seconds. The user can then change the shot delivery rate by pressing the UP or DOWN button. Pressing and holding the UP and DOWN buttons for 2 seconds saves the mode and the desired cycle rate.

Operation Mode Details

Mode 1 - Repeat cycle on power up

When powered on, the Pulse R™ cycles output at the rate displayed (indicated in cycles/min.) until power is removed or turned off. The rate can be adjusted from 1 to 250 cycles/min. The duty cycle (on/off time of each cycle) is automatically set by the Pulse R™.

Appendix E: Pulse R™ Operating Modes and Faults

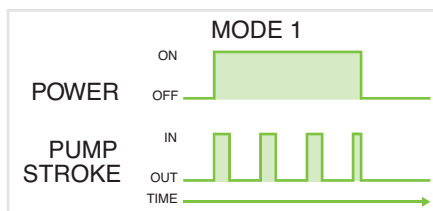

Figure 40: Mode 1 timing diagram

Mode 3 – Deliver shots on power up

When powered on, the Pulse R™ rapidly cycles output to deliver the selected number of shots. Once power is turned off, The Pulse R™ resets and will deliver the selected number of shots the next time power is turned on. In mode 3, the first digit on the display will flash “S”. The value can be adjusted from 1 to 99. The rate of these shots is determined when selecting the mode. See *Changing Operation Modes* on the previous page for more detail.

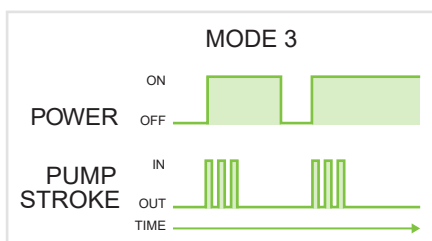

Figure 41: Mode 3 timing diagram

Appendix E: Pulse R™ Operating Modes and Faults

Locking the Display

To prevent accidental changes, the display can be locked by pressing and holding the UP and DOWN buttons simultaneously for 3 seconds. The display will show **L 0 0** for 1 second, and then show the setpoint for the current mode. Anytime a user interacts with the UP or DOWN button, the system will display **L 0 0** for 1 second.



Figure 42: Locking keypad

To unlock, press and hold the UP and DOWN buttons simultaneously for 3 seconds. The display will show **U L 0** for 1 second and then show the setpoint for the mode.



Figure 43: Unlocking keypad

Fault Indication

An illuminated red light between the UP and DOWN buttons indicates that a fault condition is or was previously present. This light will be accompanied by an FXX fault code.



Figure 44: Fault indication

The system will attempt to operate normally regardless of the fault state. **Faults can be cleared when the fault state is no longer active and the user has pressed the UP or DOWN button.**

Appendix E: Pulse R™ Operating Modes and Faults

F01 = Output circuit error

An F01 error indicates one of three possibilities:

1. An open circuit is detected. Check to ensure that the Pulse R™ is appropriately connected to the solenoid valve.
2. A short circuit is detected. Check for any shorts in the system on the output side of the Pulse R™.
3. A valve that is not 24VDC is connected to the Pulse R™.

F02 = Major system fault

An F02 error indicates that the system has detected an issue within the memory or processor. If you see a persistent F02 error code, clear the error code by powering the Pulse R down and back up and then pressing either the UP or DOWN button on the control panel. If the F02 error code persists, there may be an issue with the memory or processor that cannot be resolved. Contact Unist for a replacement system.

F03 = Incoming voltage out of range

An F03 error indicates that the incoming voltage is outside of the allowable range. The incoming power must be 24VDC +/- 10%.

Appendix F: Trimming Coaxial Tubing

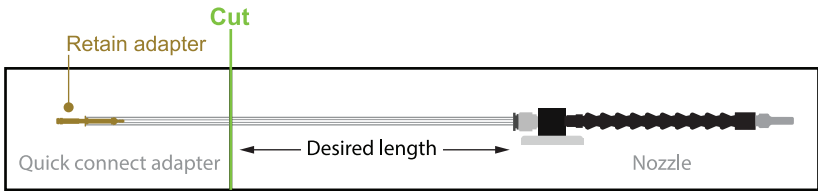

- 1 Using tubing cutters, cut nozzle output tubing to the desired length.



- 2 Carefully trim outer and inner tubing from quick connect adapter, ensuring the brass barb is not scratched or damaged.

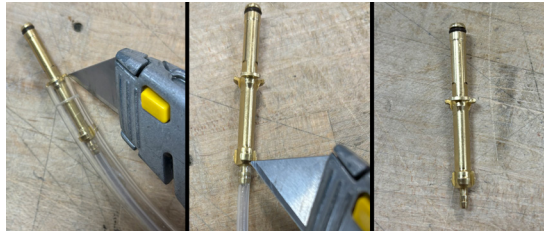

- 3 Pull out approximately 1" of inner tubing, trim and reinstall quick connect adapter to the tubing. Ensure inner and outer tubing is fully seated.

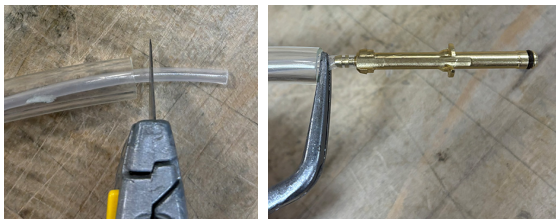

- 4 Connect to appropriate pump output connector.



Appendix G: Enclosure Mounting Template

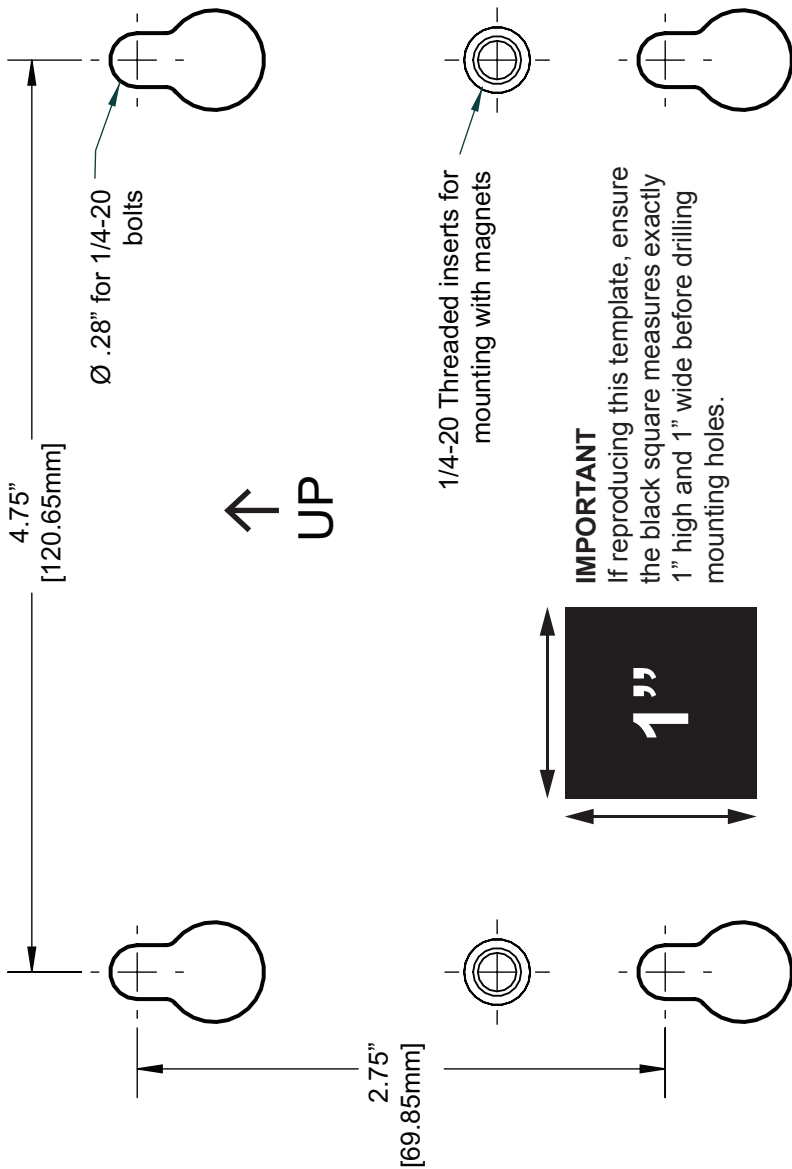

Appendix G: Enclosure Mounting Template

This page was intentionally left blank



Unist, Inc.
4134 36th Street SE
Grand Rapids, MI 49512 USA
U.S. & Canada: 800.253.5462
International: 616.949.0853
Email: salesupport@unist.com

MANUMST